



Simbeor THz

Electromagnetic Signal Integrity Software to Design Predictable PCB/Packaging Interconnects

What is new in Simbeor 2022

www.simberian.com

- *New capabilities in Simbeor SDK...*
- *SI Compliance Analyzer...*
- *3DTF Acceleration...*
- *Multi-Via enhancements...*

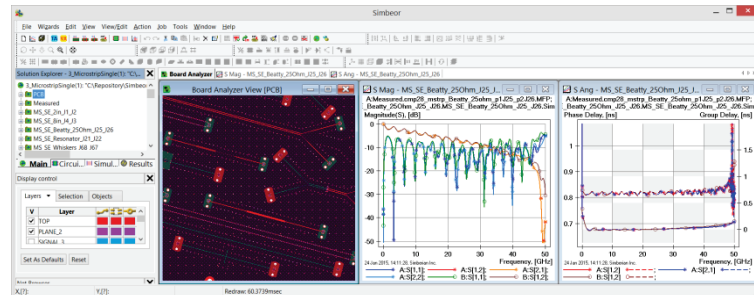

Data rates in consumer/communication electronics

PCI Express and DDR will probably dominate in all types of electronics;

Runners up: USB, Ethernet, SAS, InfiniBand, CEI...

Data rate per single link (Package/PCB)

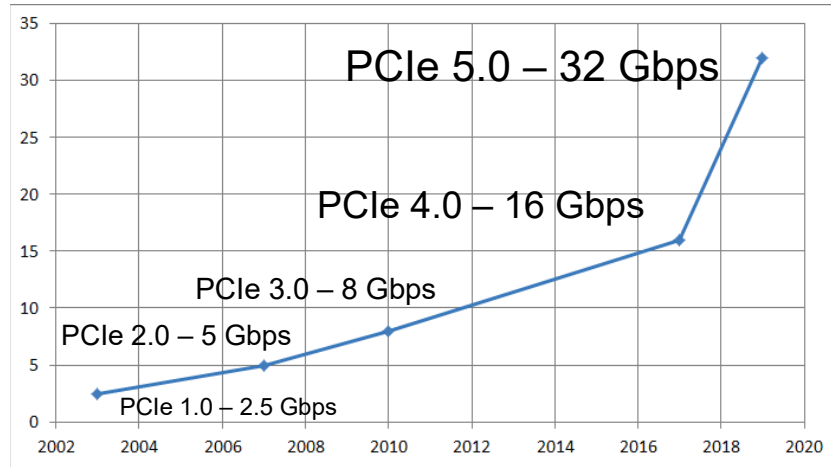

Data rates double almost every 3 years

Around 1 billion devices will run on PCIe5 in 2-3 years

(M. Mazumder, Intel Corp. – DesignCon 2019)

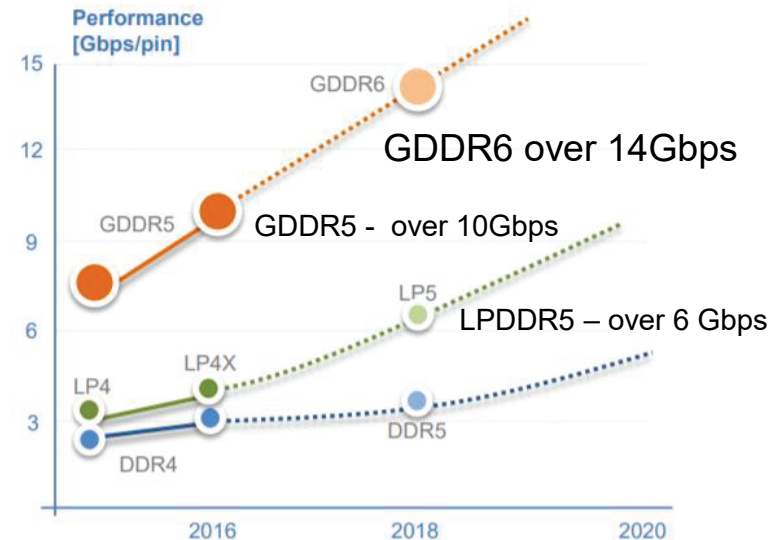

[source : B. Koo, DesignCon 2019, HOT Chips, SAMSUNG]

Typical PCI Express architectures

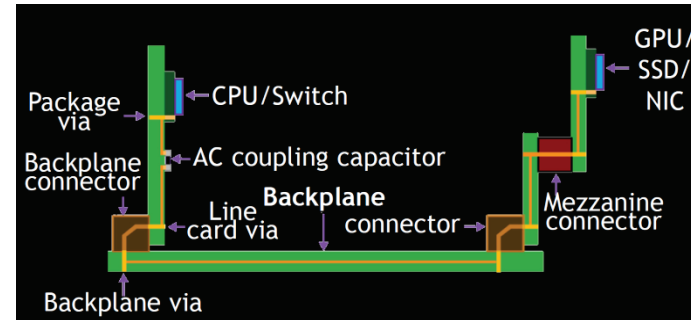
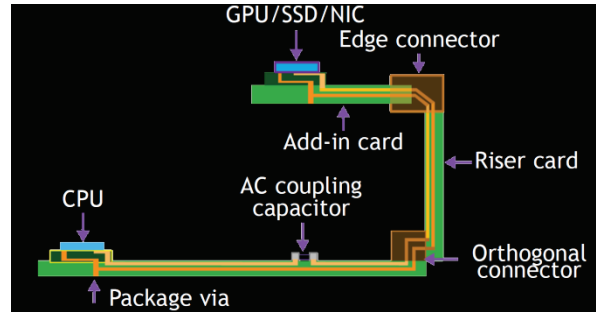
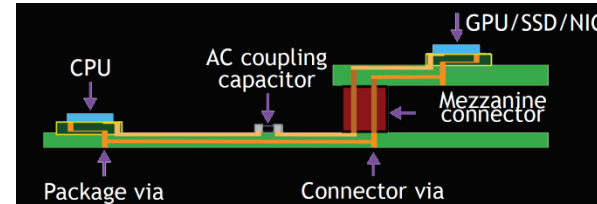
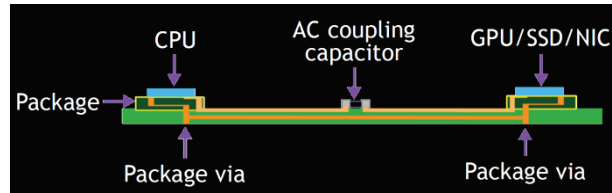

PCB design task: make sure that PCB interconnects and complete link satisfy compliance metrics for a particular standard (loss, dispersion, reflections, crosstalk, mode conversion, COM, ERL...)

It requires electromagnetic models for transmission lines and discontinuities

Simbeor is complete solution for ALL PCB/package interconnect design tasks

Simbeor enables **geometry synthesis** for controlled impedance transmission lines and via-holes, has **geometry import** and selection capabilities, and **3D geometry editor**

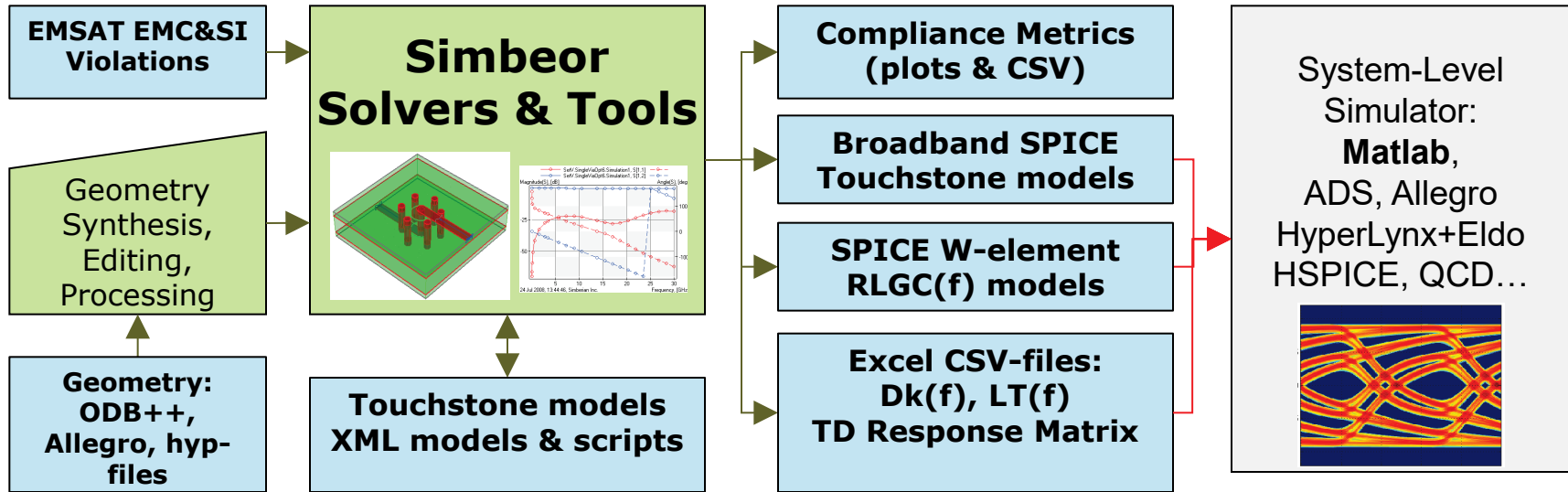

Simbeor is one-stop solution for passive interconnect pre and post-layout analyses with advanced electromagnetic models, for macro-modeling and material parameters identification tasks, and deembedding

All Simbeor technologies are now available in Simbeor SDK!

Simbeor solvers and algorithms

- ❑ Simbeor 3DML – full-wave 3D analysis tool for multi-layered geometries
 - Hybrid solver: Method of Lines + Trefftz Finite Elements + Method of Simultaneous Diagonalization (de-embedding)
 - Analysis of discontinuities and transmission lines with high-frequency (non-TEM) dispersion and anisotropy (any planar cross-section)
- ❑ Simbeor 3DTF – full-wave 3D analysis with Trefftz finite elements
 - Potential applications: power-delivery networks (1D+2D), connectors and packaging (3D), THz and optical circuits
- ❑ Simbeor 3DML and 3DTF solvers are parallelized locally and with distributed computing (through our own cloud computing framework)
- ❑ Fast EM solver for via geometry synthesis and analysis below 3 GHz (assumes infinite planes)
- ❑ Simbeor SFS – unique quasi-static field solver for large t-line cross-sections (any planar cross-section)
 - MoM, supports all dispersive isotropic dielectric models (7 models) and roughness models (6 models)
- ❑ Linear Network Solvers – unique port-based analysis
 - 7 solvers for FD and TD analysis of multiport networks based on Y or S-parameters – sparse solvers for extremely large networks
 - **Material parameters identification, test fixture extraction and de-embedding capabilities**
- ❑ Rational Compactor – converts discrete S-parameter models into frequency-continuous rational macro-models
- ❑ **All solvers are available in Simbeor SDK with API for C/Python/Matlab**

Simbeor SFS

- ❑ Quasi-static field solver based on Method of Moments (MoM)
- ❑ Takes geometry of traces in layered media (rectangular trapezoidal, hat-shape, butterfly or hexagonal trace shape) and realistic conformal solder mask defined by 2 parameters
- ❑ Traces can be in signal as well as in plane layers (conformal metallization)
- ❑ Accounts for the dispersion in dielectrics (11 dielectric models), conductor skin-effect and skin-effect on rough surface (7 unified multi-level roughness models defined with 2 parameters per level)
- ❑ Can be used to identify single-ended and differential trace width/spacing for a given impedance (synthesis) or compute characteristic impedance, delay and attenuation at a given frequency (analysis)
- ❑ Computes frequency-dependent modal and RLGC parameters to evaluate delay, losses and cross-talk
- ❑ Outputs tabulated W-element – frequency-dependent R, L, G and C matrices in HSPICE-compatible format
- ❑ Covers all configurations in Polar tools and much more with more advanced algorithms and higher accuracy!
- ❑ **Available in Simbeor SDK**

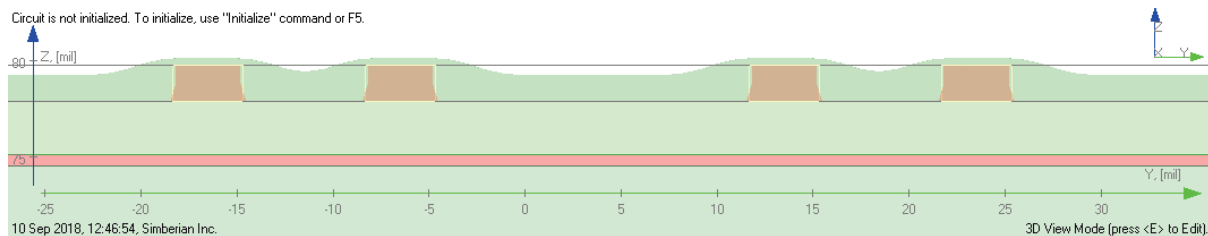

Simbeor 3DML

- ❑ Full-wave 3D analysis tool for multi-layered geometries (planar 3D)
- ❑ Faster analysis of smaller structures with high accuracy
- ❑ Hybrid solver:
 - Method of Lines – similar to Method of Moments
 - Trefftz Finite Elements are used inside conductors
 - Method of Simultaneous Diagonalization used for precise de-embedding
- ❑ Analysis of discontinuities and transmission lines with high-frequency (non-TEM) dispersion and anisotropy (any planar cross-section), interconnects with meshed planes
- ❑ Available in SDK for analysis of any 3D multi-layered geometry
- ❑ Frontal accelerator added in Simbeor 2021 – much faster and no loss accuracy

Y.O. Shlepnev, "Extension of th Method of Lines for planar 3D structures" - in Proceedings of the 15th Annual Review of Progress in Applied Computational Electromagnetics (ACES'99), Monterey, CA, 1999, p.116-121.

Simbeor 3DTF

- ❑ 3D full-wave solver based on unique Trefftz finite element method (should not be confused with Ultra weak Discontinuous Galerkin Wave Elements)
- ❑ Analysis of discontinuities, transmission lines and periodic structures
- ❑ Unique field visualization capability (E, H, currents, **power flow density**,...)
- ❑ Current version uses structural adaptive mesh – it restricts complexity of geometry
- ❑ To make it more capable, it needs adaptive conformal hexahedral or hybrid meshing
- ❑ Theory of hexahedral elements and adaptive elements is developed and tested in prototype
- ❑ Potential applications: advanced power and signal integrity (1D+2D+3D), connectors, packaging, THz interconnects,...
- ❑ **Available in SDK for analysis of any 3D multi-layered geometry with possible 3D objects**

Power flow density in coupled differential vias computed with Simbeor 3DTF

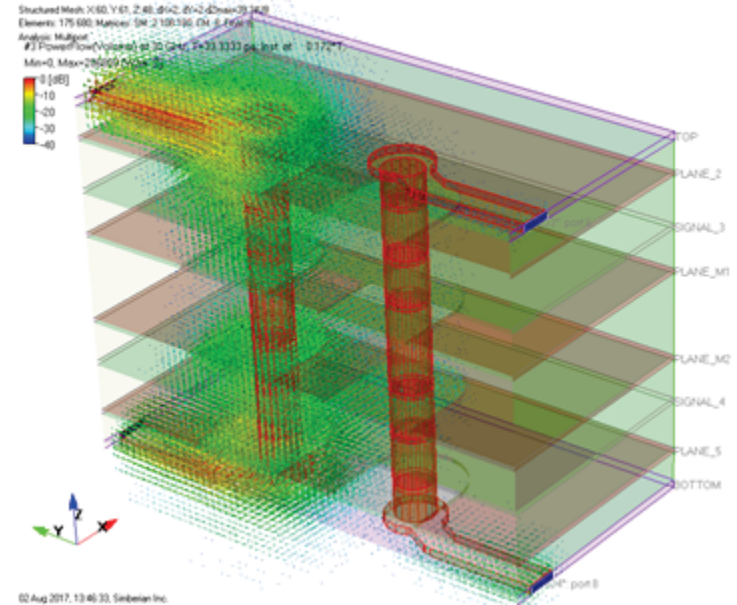

Trefftz Finite Elements in a nutshell

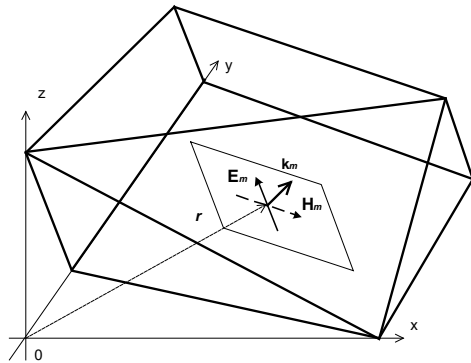

Simple and robust!



Element interior fields (based on exact solution of Maxwell's equations):

$$\begin{pmatrix} \bar{E}(\bar{r}) \\ \bar{H}(\bar{r}) \end{pmatrix} = \sum_{m=1}^{N_{\text{int}}} \left[A_m^+ \cdot \begin{pmatrix} \bar{E}_{0m} \\ -\bar{H}_{0m} \end{pmatrix} \cdot e^{ik_0 \bar{k}_m \cdot \bar{r}} + A_m^- \cdot \begin{pmatrix} \bar{E}_{0m} \\ \bar{H}_{0m} \end{pmatrix} \cdot e^{-ik_0 \bar{k}_m \cdot \bar{r}} \right], \quad \bar{r} \in \Omega_p$$

$$\bar{k}_m \cdot \bar{E}_{0m} = 0, \quad \bar{H}_{0m} = \frac{\bar{k}_m \times \bar{E}_{0m}}{Z_0}, \quad k_0 = \omega \sqrt{\epsilon \mu}, \quad Z_0 = \sqrt{\mu / \epsilon}$$



Projection on boundaries

$$\bar{b}_{el} = [S_{el}] \cdot \bar{a}_{el}$$

S-parameters of Trefftz element



$$\bar{b} = [S] \cdot \bar{a}$$

S-parameters of complete structure

1. V.V. Nikol'skii, T.I. Lavrova, "The method of minimum autonomous blocks and its application to waveguide diffraction problems," *Radio Engineering & Electronic Physics*, vol. 23, no. 2, p.1-10, 1978.
2. V.V. Nikol'skii, T.I. Nikol'skaia, *Decompositional approach to electromagnetic problems*. Moscow: Nauka, 1983 (in Russian).
3. Y.O. Shlepnev, Trefftz finite elements for electromagnetics. - *IEEE Trans. on Microwave Theory and Techniques*, vol. MTT-50, pp. 1328-1339, May, 2002.

Analysis of networks with S-parameters

- ❑ Simbeor Multiport File Processor (MFP, available in SDK)
 - Everything for S-parameter models in Touchstone format – reading, writing, all types of conversions, post-processing, quality evaluation
 - Conversion into rational macro-model (unique passive vectfit) and into Broadband SPICE macro-model
- ❑ Simbeor Linear Network Solver (LNS, available in SDK)
 - Everything needed for frequency (AC) and time-domain (TD) analysis of networks composed of S-parameter models, transmission line segments, discontinuities (models built in Simbeor) and package models (RLGC circuits)
 - TD analysis includes simple models for transmitters and receivers (step, pulse, bit streams with jitter)
 - Computes S-parameters or pulse response for external IBIS-AMI or COM analysis
 - Recursive convolution can be used with an external SPICE solver for analysis with IBIS or SPICE models for transmitters and receivers

Simbeor tools

- ❑ Touchstone Analyzer™ – S-parameters plotting, quality assurance and macro-modeling
- ❑ Transmission line wizard – fast synthesis of any single-ended and differential line geometry (strip, micro-strip, CPW, CBCPW,..., available in SDK)
- ❑ Via Analyzer™ – fast synthesis of via-holes and launches geometry
- ❑ Multi-layered geometry editor for pre and post-layout analyses
- ❑ Linear Network editor to draw multiport networks (link path models)
- ❑ SiTune™ – via, t-line geometry, linear network optimization, material model identification (available in SDK)
- ❑ Eye Analyzer™ - measurements on eye diagram (available in SDK)
- ❑ ICN Analyzer™ - for Integrated Cross-talk Noise (ICN) computation
- ❑ Board Analyzer™ - unique post-layout de-compositional electromagnetic analysis
 - DeComposer™ - automatic decomposition for post-layout analysis of coupled and skewed links
- ❑ Violation Browser™ - viewer for EMSAT rule checker (IBM)
- ❑ SPP Analyzer – material model identification with TDT or short pulse measurements (IBM)
- ❑ T-Resonator Analyzer – extraction of loss tangent with T-resonator (available in SDK)
- ❑ Multiple Kits for Matlab – MLKit, TLineKit, SIPlotKit, ViaDevKit,...

Available for 15-day trial at www.simberian.com

Simbeor is formally validated up to 50 GHz

EXAMPLE

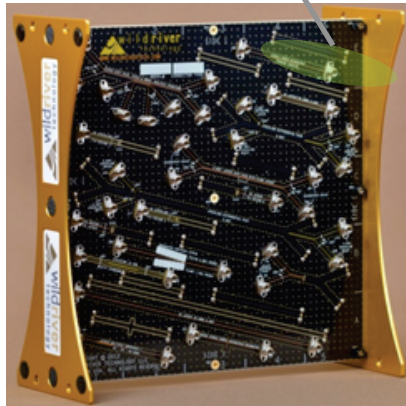
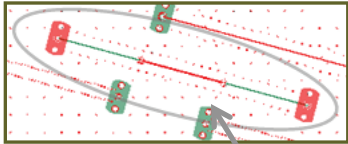

CMP-28 Channel Validation Platform from Wild River Technology LLC

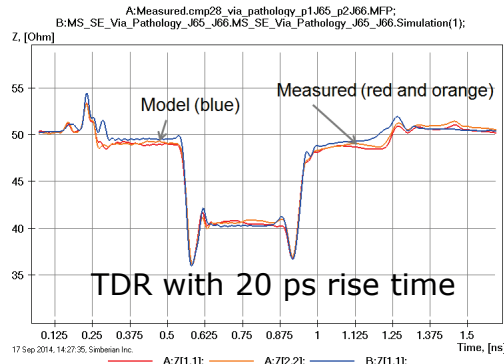
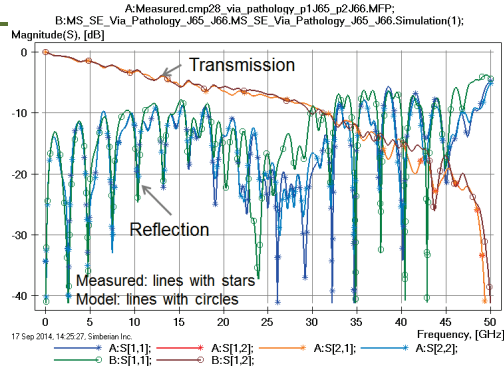

See Webinar #4. Complete description of CMP-28/32 platforms with all results is available at http://www.simberian.com/Presentations/CMP-28_Simbeor_Kit_Guide.pdf

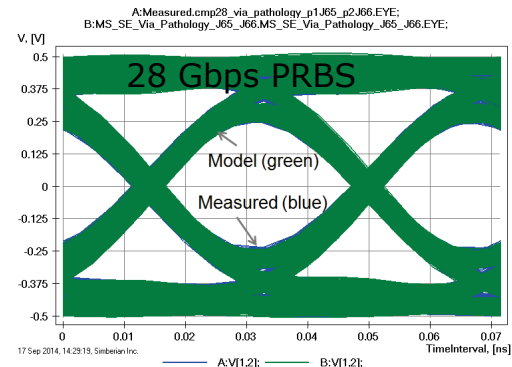
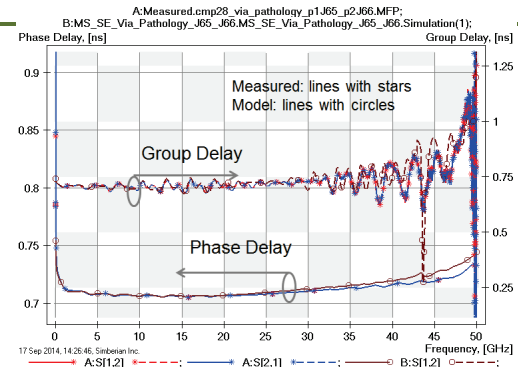

Example of systematic validation with EvR-1 test board from Infinera

1.1 in microstrips – vias – 1.5 in strips – vias – 1.1 in microstrips

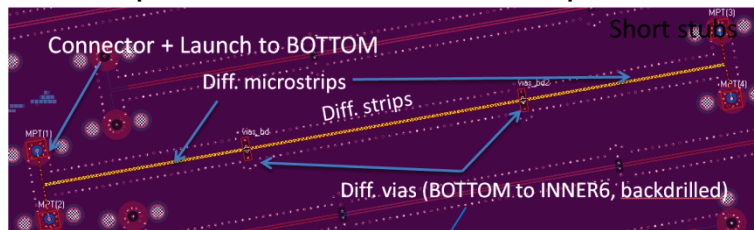

Backdrilled vias model

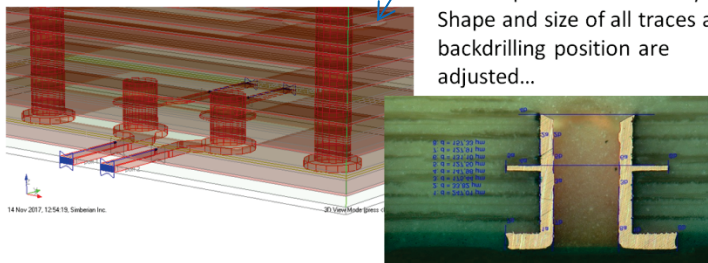

De-compositional EM analysis
Shape and size of all traces and backdrilling position are adjusted...

Complete report #2018_01 at
<http://www.simberian.com/AppNotes.php>

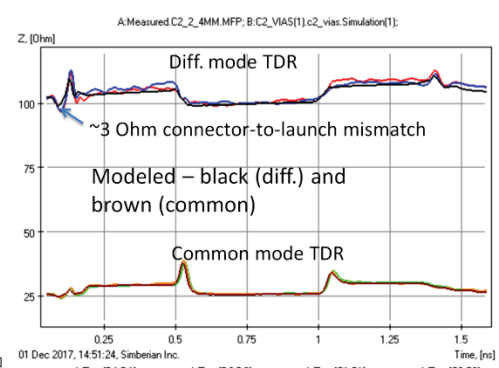
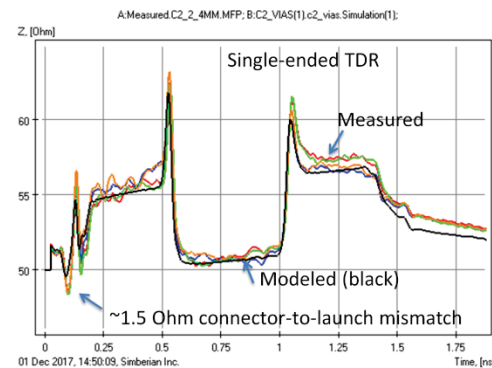
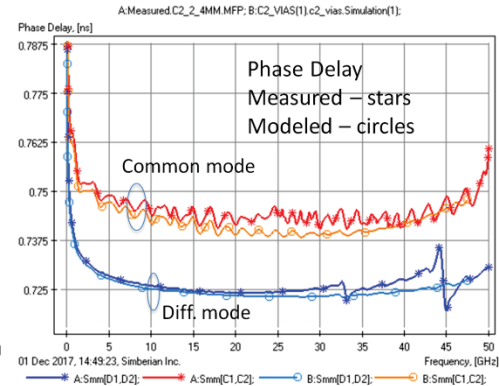
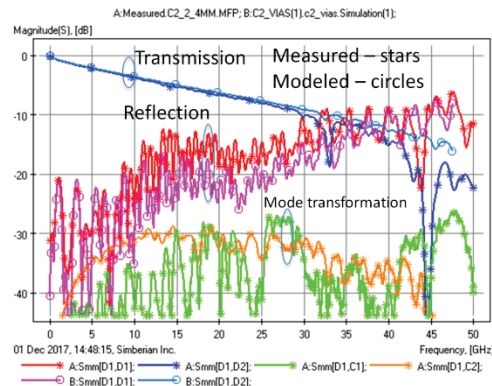

28 Gbps NRZ, PRBS-32, 15 ps rise time

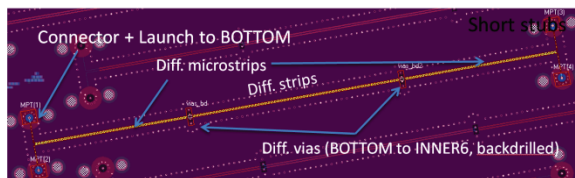

Backdrilled vias model

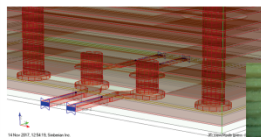

De-compositional EM analysis
Shape and size of all traces and
backdrilling position are
adjusted...

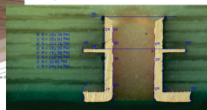

A: Measured C2_2_4MM.28gbps; B: C2_VIAS(1).c2_vias.28gbps;

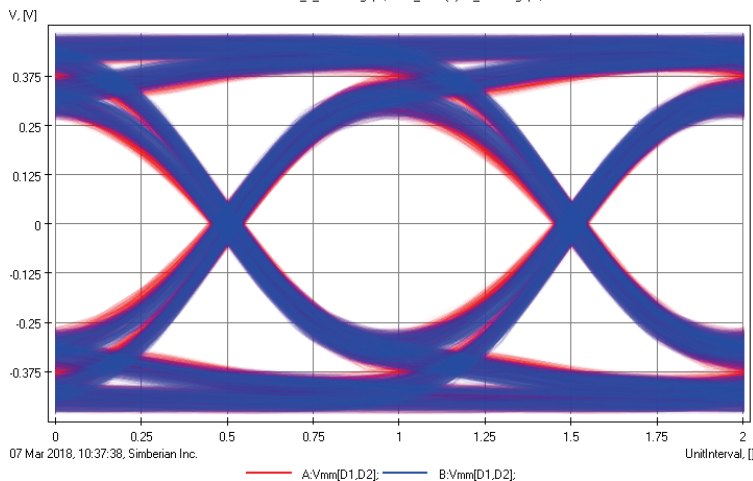

Eye Analyzer

Show Eye Metrics: Selected Auto-open

Parameter	Measured.C2_2_4M...	C2_VIAS(1).c2_vias....
Eye Level Zero (V)	-0.370953	-0.373448
Eye Level One (V)	0.371227	0.375322
Eye Level Mean (V)	-8.25219e-005	0.00123696
Eye Amplitude (V)	0.74218	0.74877
Eye Height (V)	0.504704	0.526895
Eye Width (UI)	0.883814	0.898891
Eye Opening Factor	0.680029	0.703681
Eye Signal to Noise	6.45773	6.10486
Eye Rise Time (20-80) (UI)	0.459316	0.42801
Eye Fall Time (80-20) (UI)	0.460037	0.427404
Eye Jitter (PP) (UI)	0.116186	0.101109
Eye Jitter (RMS) (UI)	0.0279181	0.0240858

28 Gbps NRZ: model – blue, measured – red; 5.5% difference in eye heights and 1.5% in heights
EvR-1 test board – see complete report at Complete report #2018_01 at
<http://www.simberian.com/AppNotes.php>

Use of Simbeor technologies

- ❑ Dielectric and **conductor roughness** model identification (4 methods) – to ensure accuracy
- ❑ Pre- and post-layout de-compositional electromagnetic analysis or PCB/package interconnects
 - Stackup design – t-line synthesis/analysis for all PCB/package applications (no restriction)
 - Viahole design for low-speed applications (based on fast EM solver, coming up)
 - Broadband viahole optimization for serial or point-to-point links (use of 3DML and 3TDF solvers and optimization, coming up)
 - Impedance, loss, mode conversion, reflection (vias) and cross-talk control during layout process
- ❑ Complete link analysis: S-parameters, compliance metrics, TDR/TDT, eye diagrams, pulse response (for COM metrics)
- ❑ Scripting in C/C++/Matlab/python for design automation, material identification and machine learning

Simbeor SDK

- ❑ Simbeor SDK is dynamic link libraries with API in C language for programming or scripting in C/C++, Matlab and Python
- ❑ It provides access to all Simbeor solvers and some tools and can be used for...
 - **design automation** – scripted EM analysis, geometry synthesis, complete link analysis, material model identification...
 - **machine learning** – training or complimenting machine learning algorithms...
 - **integrating into your EDA tools** (Stack Manager in Altium Designer 19)

Why use Simbeor?

1. Algorithms are systematically and independently validated with measurements up to 50 GHz!
2. Unique algorithms for material models identification – must be the basis of systematic approach to design predictable interconnects
3. Advanced and verifiably accurate models of transmission lines
4. Unique EM models for flexible interconnects and periodic structures
5. Unique macro-modeling capabilities for consistent FD and TD analyses of networks with t-lines and S-parameter models
6. Unique de-embedding capabilities (part of LNS)
7. Advanced and verifiably accurate models of discontinuities (vias, pins,...)
8. Unique de-compositional capabilities for chip-to-chip link analysis (no artifacts on the boundaries)

Simbeor 2022

- ❑ New functions and Kits in Simbeor SDK - https://kb.simberian.com/browse_item.php?id=1090
- ❑ Lua scripting in Simbeor THz for design automation
 - Possibility to use distributed computing (parallelization) from Matlab or Python scripts - https://kb.simberian.com/browse_item.php?id=1091
- ❑ New options and improvements for Multi-Vias - https://kb.simberian.com/browse_item.php?id=1094
- ❑ New Node element in Linear Network for easier analysis of multi-drop links - https://kb.simberian.com/browse_item.php?id=1095
- ❑ 3D SI View in Board Analyzer - https://kb.simberian.com/browse_item.php?id=1092
- ❑ 3DTF solver acceleration with domain decomposition and frontal solver
- ❑ SI Compliance Analyzer with consistent ERC, Fast SI, 3D SI analyses modes
- ❑ New licensing options – low cost Simbeor Verify license (ERC + Fast SI)

What is next?

- ❑ More material on the solvers and algorithms available upon request – info@simberian.com
- ❑ Simbeor SDK is available for customers and OEM solutions at Downloads section of www.simberia.com
- ❑ To try and get familiar with solvers and algorithms, download Simbeor from www.simberian.com and get free trial license

???